

Hex Code Table		
✓ FMXXXX	Length (L)	
FM0530	1	
FM0531	2	
FM0532	3	
FM0533	4	
FM0534	5	
FM0535	6	
FM0536	7	
FM0537	8	
FM0538	9	
FM0539	10	
FM0540	11	
FM0541	12	
FM0542	13	
FM0543	14	
FM0544	15	
FM0545	16	
FM0546	17	
FM0547	18	
FM0548	19	
FM0549	20	
FM0550	21	
FM0551	22	
FM0552	23	
FM0553	24	
FM0554	25	
FM0555	26	
FM0556	27	
FM0557	28	
FM0558	29	
FM0559	30	
FM0560	31	
FM0561	32	
FM0562	33	
FM0563	34	
FM0564	35	
FM0565	36	
FM0566	37	
FM0567	38	
FM0568	39	
FM0569	40	
FM0570	41	
FM0571	42	
FM0572	43	
FM0573	44	
FM0574	45	
FM0575	46	
FM0576	47	
FM0577	48	
FM0578	49	
FM0579	50	
FM0580	51	

Metric Spacers 6 mm

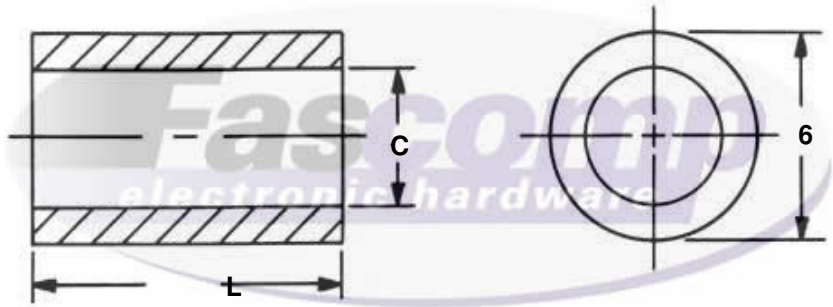

Create a part number:

Length	Clearance	Material	Finish
FMXXXX	XX	XX	XX
_____ . _____ . _____ . _____			

Hole Clearance Code (XX)			
✓	Code (XX)	Thread	C +0.3 -0.0
	3	M3	3.2
	35	M3.5	3.7
	4	M4	4.3

Material		
✓	Material Code (XX)	
	A	Aluminum
	B	Brass
	S	Steel
	SS	Stainless Steel
	N	Nylon

**Tolerances
Unless otherwise Specified**
 .xxx +/- .13mm
 .xx +/- .26mm
 Angular +/- 1 Degree
 Linear +/- .13mm
Break all sharp edges

✓ Compatible Finish		
A, B, S, SS	0 - Plain	
B, S	5 - Nickel Plate (QQ-N-290)	
A	6 - Iridite #14 Gold (MIL-C-5541E)	
A	7 - Iridite Clear (MIL-C-5541E)	
A	9 - Alodine 1200	
B, S	12 - Zinc Clear (ASTM-B-633)	
B, S	16 - Electro Tin (MIL-T-10727 TYPE 1)	
SS	20 - Passivation (MIL-F-14072D)	
A	22 - Clear Anodize (MIL-A-8625-TYPE2) (Sulphuric) Hot Water Seal (Clear)	
A	24 - Black Anodize (MIL-A-8625)	
B, S, SS	26 - Black Oxide	
B, S	28 - Zinc Yellow (ASTM-B-633)	



Source Control Drawing:
To be produced by
Fascomp Electronic Hardware

This document is the property of Fascomp Inc. and shall not be reproduced, distributed, or used as a basis for manufacturing without written permission from Fascomp Inc.